

SMA-221001-R

Original instructions

PNEUMATIC POLISHER TYPE PA-2 INSTRUCTION MANUAL

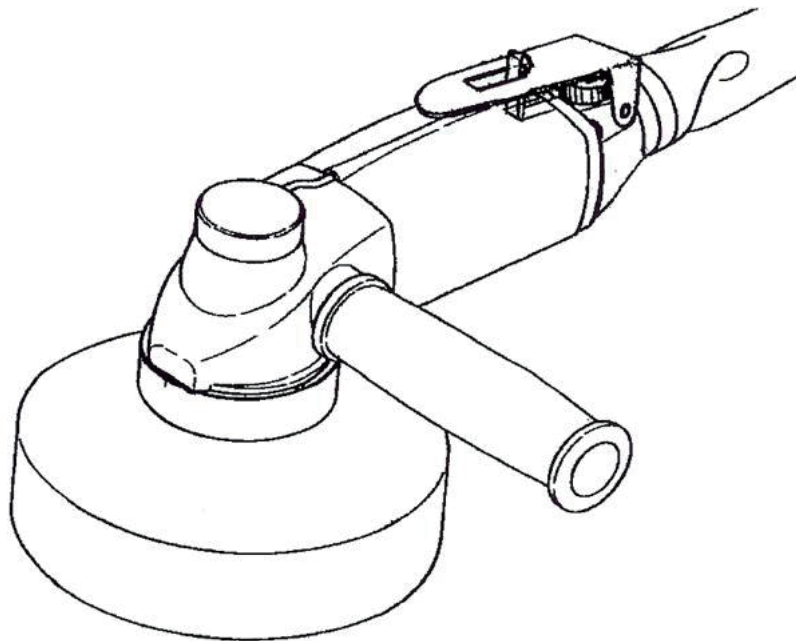



For accident prevention and safety operation, before use, carefully read this instruction manual and follow the instructions, warnings and cautions given therein. Further, store this instruction manual at a place where operator and maintenance staff can access thereto easily anytime as necessary.

Thank you for purchasing our PNEUMATIC POLISHER TYPE PA-2.
 Before use, carefully read this instruction manual for safety and efficient operation through full understanding of the operating instructions, warnings and cautions as well as its performance.

MEANING OF SYMBOLS

Improper handling of this polisher would cause hazardous accidents and injuries. Hazards and damages that may arise from improper handling are classified into two categories; WARNING and CAUTION depending on the degree of them.

 WARNING	Incorrect handling, that is, failure to follow the warnings and cautions given in this instruction manual could cause death or serious injuries of operator.
 CAUTION	Incorrect handling, that is, failure to follow the cautions and instructions given in this instruction manual could cause injuries of operator or otherwise physical damage.

DECLARATION

DECLARED DUAL-NUMBER NOISE EMISSION VALUES IN ACCORDANCE WITH ISO 4871

Measured A-weighted sound power level, L_{WA} , in decibels Uncertainty, K_{WA} , in decibels Measured A-weighted emission sound pressure level, L_{pA} at the operator's position, in decibels Uncertainty, K_{pA} , in decibels	96.9 0.73 85.9 0.73
Values determined according to noise test code given in ISO 15744. Note – The sum of a measured noise emission value and its associated uncertainty represents an upper boundary of the range of values which is likely to occur in measurements.	

DECLARED VIBRATION EMISSION VALUE IN ACCORDANCE WITH EN 12096

Measured vibration emission total value a 1.48m/s^2 Uncertainty K 0.32m/s^2
Values determined according to ISO 8662-8.

CONTENTS

WARNINGS AND CAUTIONS FOR SAFETY OPERATION	3
1. GENERAL	
2. OPERATIONAL ENVIRONMENT	
3. WORKING CLOTHING AND PROTECTIVE EQUIPMENT	
4. APPROPRIATE INSERTED TOOL	
5. OPERATOR'S KNOWLEDGE TO USE THIS POLISHER	
6. POLISHING AT HIGH WORKPLACE	
7. ELECTRICAL INSULATING	
NAME OF PARTS	6
STANDARD ACCESSORIES	6
OPTIONS	7
SPECIFICATIONS	8
APPLICATION	8
CHECK ITEMS BEFORE OPERATING	9
PREPARATIONS BEFORE OPERATING	10
HOW TO POLISH	15
AFTER USE	18
MAINTENANCE AND CHECK	19
TROUBLESHOOTING	19
DISPOSAL OF POLISHER	19
CONTACT LIST	20
EC Declaration of Conformity	21

•WARNINGS AND CAUTIONS FOR SAFETY OPERATION

Proper operation and periodic maintenance are indispensable for long-term use of this polisher with safety. Carefully read the safety warnings and cautions given in this instruction manual, and do not start polishing operation and maintenance work until full understanding of the descriptive contents.

1. GENERAL

This polisher is equipped with rotating parts. During rotation of the polisher, the operator shall hold the polisher by both hands; one hand grips the grip bar (see Figure 2, 3 and 4, page 6 and 7), another does the polisher body around the switch lever. In any cases during rotating, anybody shall not touch the rotating parts of the polisher. Holding by one hand is prohibited because another hand would have risk to touch the rotating parts. When controlling airflow or water-flow, one hand shall hold the grip bar and another hand would adjust the airflow control valve or the water-flow control valve under OFF condition.

2. OPERATIONAL ENVIRONMENT

 WARNING
<ul style="list-style-type: none">· DO NOT ALLOW ANY OTHER OPERATORS TO ACCESS TO THE POLISEHR Do not allow any other operators except specific operators to access to the work place. Particularly be careful not to allow children to access the working area.· CAUTION AGAINST EXPLOSION AND FIRE Do not use the polisher absolutely in potentially explosive atmospheres to prevent explosion and fire.

 CAUTION
<ul style="list-style-type: none">· KEEP A WORKPLACE IN ORDER Keeping a worktable and peripheries disordered could cause a drop of the polisher and the fraction is caught in the polisher. This is very hazardous. Be careful to keep the workplace and its peripheries in order.

3. WORKING CLOTHING AND PROTECTIVE EQUIPMENT

 WARNING
<ul style="list-style-type: none">· WEAR APPROPRIATE PROTECTIVE EQUIPMENT Operator engaged in polishing operation shall wear protective glasses, safety shoes, rubber gloves and protective cap. At a dusty place, inhaling dust and powder could cause respiratory diseases at throat and lungs. Therefore, when polishing in such an environment, make sure to put a dust mask on. Furthermore, when using the polisher, put a pair of earplugs on to prevent ear disease.

 CAUTION

- WEAR PROPER PROTECTIVE CLOTHING
Do not wear a pair of knitted gloves and work clothing with lower-sleeve edge opened. Wearing such gloves and loose clothing as well as long hair could be drawn in or trapped of by the rotating parts of the polisher.

4. APPROPRIATE INSERTED TOOL
(TOOL INSERTED IN THE HAND-HELD POWER TOOL TO PERFORM POLISHING)

 WARNING

- DO NOT MOUNT ANY INSERTED TOOLS EXCEPT THE ONES FOR POLISHING
This polisher shall not be used for cutting. Solid inserted tools will cause injuries. Do not mount any inserted tools to this polisher which are not intended for the polishing operation such as grinding wheel, cutting-off wheel and dish wheel.
- THE MAXIMUM SPEED OF THE INSERTED TOOL SHALL BE HIGHER THAN THE RATED ROTATIONAL SPEED
The maximum speed of the inserted tool shall be higher than the rated rotational speed marked on the nameplate of the polisher and described in SPECIFICATIONS in page 8.
- MOUNT A FLEXIBLE POLISHING PAD DESIGNED FOR THIS POLISHER
This polisher is for polishing operation fitted with flexible polishing pad and various soft materials or felt pad for polishing of surface like our DIA CERAMICA.

 CAUTION

- THIS POLISHER SHALL BE USED FOR WET-MODE OPERATION
Using dry-mode pad will cause extremely higher temperature and too much dust, resulting in fire and respiratory diseases at throat and lungs.

5. OPERATOR'S KNOWLEDGE TO USE THIS POLISHER

 CAUTION

- DO NOT USE THE POLISHER UNTIL GETTING ADEQUATE KNOWLEDGE FOR USE
Do not allow children or any other persons to operate the polisher, who do not know how to operate or cannot operate properly.

6. POLISHING AT HIGH WORKPLACE

 CAUTION

- WHEN POLISHING AT HIGH WORKPLACE, ENSURE NOBODY IS UNDERNEATH
Dropping a work piece (polishing material) or the polisher itself could cause accidents and injuries. When polishing at high workplace, the operator is recommended to take fall-down measures such as safety belt.

7. ELECTRICAL INSULATING

 WARNING
· THE POLISHER IS NOT ISOLATED ELECTRICALLY Contacting the polisher with electric supply would cause electrocution.

Attentive points : Comply with the current legislations and regulations relating to noise. Plant or shop, which uses the polisher, must use the polisher with the condition below the noise level regulated by the local administrative authority, not to disturb neighbors. A sound shield is recommended to use as necessary.

NAME OF PARTS

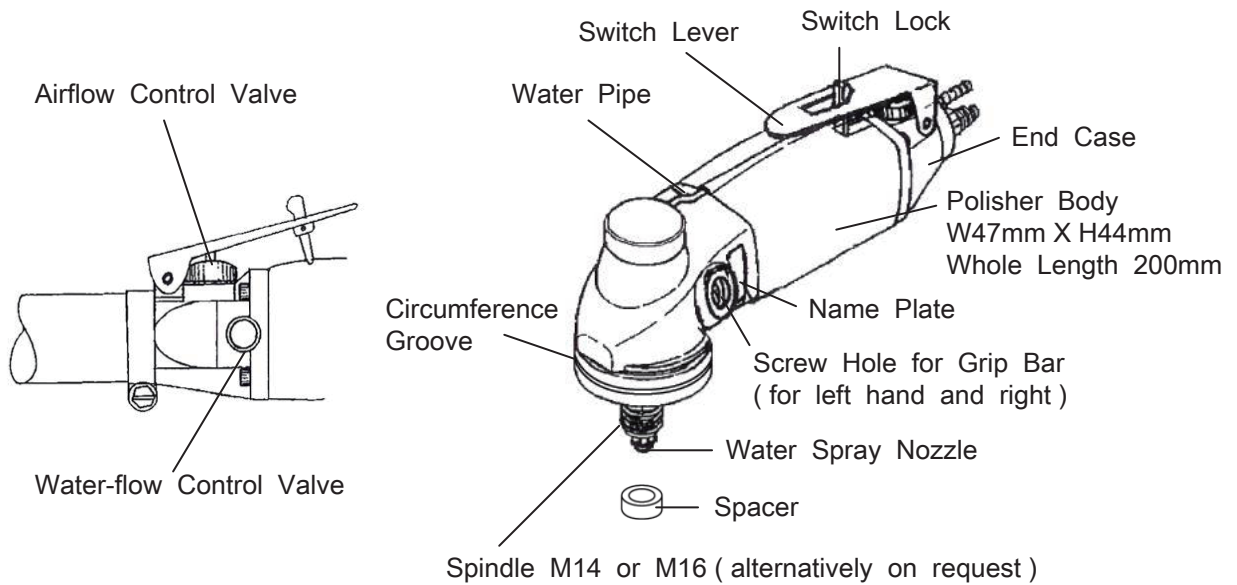

Figure 1 Control Valve

Figure 2 Name of Polisher

STANDARD ACCESSORIES

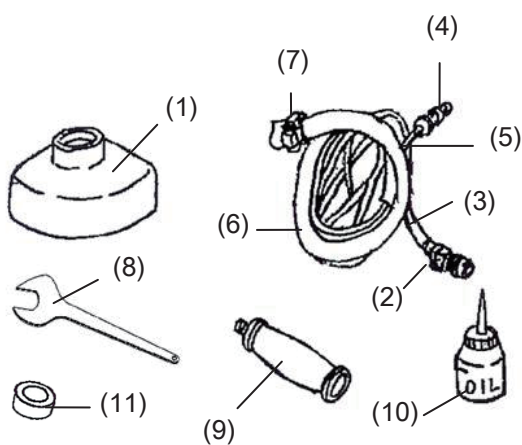

Figure 3 Standard Accessories

- (1) Water-splash skirt
 - Normal size _____ 1pc
 - Bigger size _____ 1pc
- (2) Hose fittings (Hex Nipple G1/4)- 1pc
- (3) Air hose 7X10 _____ 1pc
- (4) Couplers (for water) _____ 1pc
- (5) Flexible water hose _____ 1pc
- (6) Exhaust air duct hose _____ 1pc
- (7) Hose clamp _____ 1pc
- (8) Wrench
 - 22mm for spindle _____ 1pc
 - 26mm for rubber pad _____ 1pc
- (9) Grip bar _____ 1pc
- (10) Motor oil 30mm³ _____ 1pc
(ISO-VG46 or DIN51502DL46)
- (11) Spacer for M14 or M16
depending on spindle size _____ 1pc

TABLE 1 DIMENSIONS OF WATER-SPLASH SKIRT

Water-splash Skirt	Diameter of Applicable Rubber Pad
Normal Size with Inside Diameter 116mm	80mm and 100mm
Bigger Size with Inside Diameter 136mm	125mm

OPTIONS

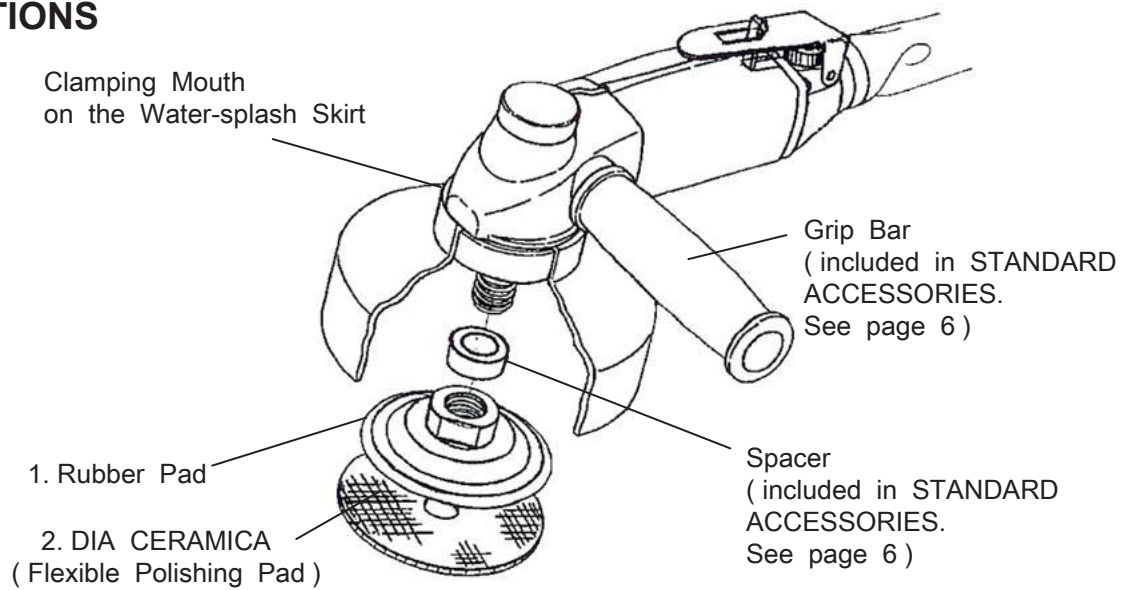

Figure 4 Options

TABLE 2 RUBBER PAD

RUBBER PAD (Nominal diameter in mm)
80, 100 and 125

TABLE 3 FAMILY OF DIA CERAMICA

DIA CERAMICA (FLEXIBLE POLISHING PAD)	
V-series (Vitrified bond)	60V, 150V, 300V
M-series (Metal bond)	60M, 150M, 300M
R-series (Resinoid bond)	150R, 300R, 500R, 1000R, 2000R, 3000R
BUFF-series	BUFF (BLACK), BUFF (WHITE)
TSUYA-series	TSUYA (BLACK), TSUYA (WHITE)

* Numbers represent mesh size (grid size) of grain contained in DIA CERAMICA respectively.

•SPECIFICATIONS

Rated no-load speed at air pressure of 0.6MPa	3,890r/min (min^{-1})
Mass (weight)	1.2kg
Maximum operating pressure of compressed air	0.6MPa
Consumption of compressed air	0.42 m^3/min at temperature 20°C and atmospheric pressure

Relation between speed and air pressure could be referred to the below Figure 5.

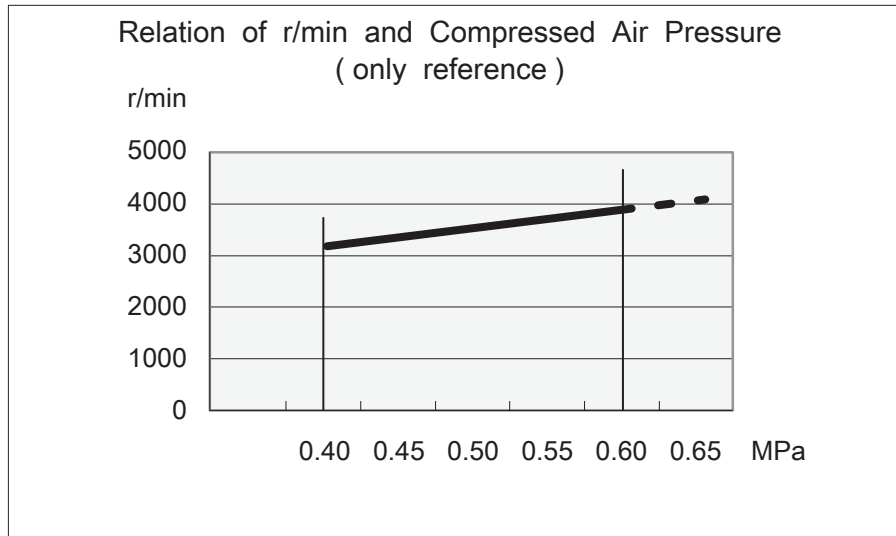

Figure 5 Relation of r/min and Compressed Air Pressure

APPLICATION

Polishing and rounding of curvatures and flat surfaces of marble, granite and terrazzo.

CHECK ITEMS BEFORE OPERATING

WARNING

- **READ THE AIR PRESSURE ON THE GAUGE**
Hold air pressure as specified before use. Operating the polisher at air pressure more than the specified value could cause damage of the polisher and the flexible polishing pad and, in the worst case, injuries to operator.
- **DO NOT USE POWER SOURCES OTHER THAN COMPRESSED AIR**
Use of high-pressure gas (e.g. oxygen, acetylene gas, propane gas etc.) could result in dangerous explosion. Do not use air other than compressed by air compressor.

CAUTION

- **DO NOT USE THE POLISHER FOR APPLICATIONS OTHER THAN SPECIFIED IN THIS INSTRUCTION MANUAL**
This polisher is exclusively for polishing stone materials. Do not apply it for grinding and polishing of metal, wood, etc.
- **CARRY OUT VISUAL INSPECTION BEFORE OPERATING**
Ensure each screw is not loose and the part are located as designated. In addition, make sure that the wrenches and/or screwdriver is not left on the polisher.

Ensure the following items before operating.

1. KEEP-IN-ORDER OF WORKPLACE

Keep the workplace in order before the start of polishing operation. When there is dust around, it would be flown by the exhaust air conducted through the exhaust air duct hose (see Figure 3 and 6, page 6 and 11). Flying dust would cause respiratory diseases at throat and lungs.

2. COMPRESSOR CAPACITY

Select and install a compressor with sufficient capacity margin for air consumption. Use of the compressed air containing water and dust could cause rusting and other troubles. Before operating, therefore, drain out water completely through the drain port provided at the bottom of the compressor tank.

3. OPERATING AIR COMPRESSED PRESSURE

This polisher is designed for operation at the maximum air pressure of 0.6MPa. Since the higher air pressure leads the higher rotational speed, do not apply the exceeded air pressure against specified to prevent the bursting of the flexible polishing pad and/or the rubber pad, which may cause injuries, and the short life of the motor of the polisher.

PREPARATIONS BEFORE OPERATING

WARNING

- MAKE THE FOLLOWING PREPARATION BEFORE OPERATING
Complete items 1, 2.1, 3, 4 and 5.1 before connecting the air hose to the compressor.
- MAKE SURE THAT THE GRIP BAR IS SCREWED IN FIRMLY
Whenever the polisher is turned ON, i.e. in test for switch function (item 7, page 13), test run (item 9, page 13) and polishing operation (HOW TO POLISH in page 15), make sure that the grip bar is screwed in firmly.

1. MOUNT THE GRIP BAR

Firmly mount the grip bar (see page Figure 2, 3 and 4, page 6 and 7)

2. THE PROCEDURE TO MOUNT AND DEMOUNT THE WATER-SPLASH SKIRT

2.1 MOUNTING OF THE WATER-SPLASH SKIRT

Attentive point : The purpose of water-splash skirt is only to decrease water splash from the water spray nozzle. As this water-splash skirt is elastic and not strong enough, this does not work as a guard.

- (1) Select a proper size of water-splash skirt according to TABLE 1 in page 6
- (2) Install the water-splash skirt on the polisher body while expanding the clamping mouth (see Figure 4, page 7) of water-splash guard from inside with fingers so that the clamping mouth fits onto the circumference groove (see Figure 2, page 6) on the polisher body

2.2 DEMOUNTING OF THE WATER-SPLASH SKIRT

- (1) Demount the flexible polishing pad and the spacer
- (2) Pull out the water-splash skirt by hand

3. PREPARE THE POLISHER

CAUTION

- CHECK FOREIGN PARTICLES
Foreign particles in the motor could cause rotating failure of the motor. Therefore, when connecting the air hose to the compressor, be careful not to let any dust, small stone, etc, into the motor.
Securely fit the flexible water hose, the air hose and the exhaust air duct hose. Failure to follow this instruction causes the disconnection and whipping of the hoses and finally injuries.
- BE CAREFUL NOT TO DAMAGE THE AIR HOSE AND THE WATER HOSE

The polisher body, the air hose and the water hose are disconnected when shipping. Connect these together as illustrated in Figure 6 in page 11.

Procedures:

- (1) Connect the water hose. For this procedure, warm up the joint part of the flexible water hose in hot water to facilitate the joint work.
- (2) Guide the hose joint (female) through the air hose in advance and tighten it. The required tightening torque is approximately 15 N m (1.53kg m). After tightening, ensure that the air hose is not disconnected even if adding tension load thereto.
- (3) Insert the exhaust air duct hose in the end case and clamp it with the hose clamp.

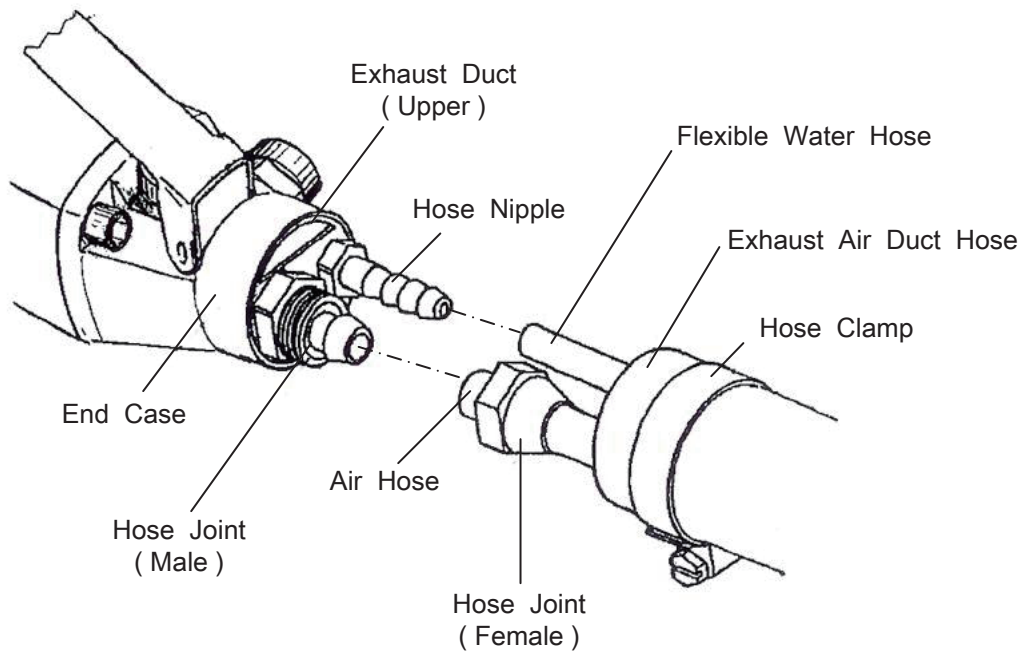

Figure 6 Connections of Hoses

4. TAKE NECESSARY MEASURES

In terms of environment, health and safety codes, take the necessary measures properly when operating the polisher, referring to DECLARATION in page 1.

5. MOUNTING AND DEMOUNTING PROCEDURES FOR THE RUBBER PAD AND THE FLEXIBLE POLISHING PAD

WARNING

- BEFORE MOUNTING OR DEMOUNTING THE RUBBER PAD AND THE FLEXIBLE POLISHING PAD, TURN OFF THE POLISHER
Before mounting or demounting the rubber pad and the flexible polishing pad, turn OFF the polisher using the switch lever without fail to prevent incidental accidents. In addition, disconnect the air hose from the compressor.
- PREVENT INCIDENTAL STARTING
When mounting or demounting the rubber pad and the flexible polishing pad on/from the polisher, disconnect the air hose from the compressor. Careless turning ON of the switch lever with the air hose connected could result in injuries.

5.1 MOUNTING OF THE RUBBER PAD AND THE FLEXIBLE POLISHING PAD

- (1) Select a combination of rubber pad and flexible polishing pad, referring to TABLE 2 and 3 in page 7
- (2) Mount the water-splash skirt in accordance with 2.1 MOUNTING OF WATER-SPLASH SKIRT
- (3) Fold back the water-splash skirt
- (4) Place the spacer through the spindle by hand
- (5) Screw in the rubber pad onto the spindle by hand
- (6) Tighten the screw using two wrenches.
The required tightening torque is approximately 15 N m (1.53kg m).
- (7) Restore the water-splash skirt to the original shape
- (8) Put the flexible polishing pad onto the rubber pad

5.2 DEMOUNTING OF THE RUBBER PAD AND THE FLEXIBLE POLISHING PAD

- (1) Peel off the exhausted flexible polishing pad from the rubber pad
- (2) Loose the rubber pads using two wrenches
- (3) The required loosening torque is approximately 15 N m (1.53kg m)
- (4) Screw out the rubber pad by hand while paying attention not to lose the spacer
- (5) For replacing, follow the procedure of 5.1 MOUNTING OF RUBBER PAD AND FLEXIBLE POLISHING PAD

6. CONNECT THE AIR HOSE TO THE COMPRESSOR

- (1) Make sure to clean out the fitting part (see Figure 3, page 6) to remove dust and foreign particles so that dust and/or any foreign particles do not contaminate inside of hoses. Contamination possibly damages the air motor.
- (2) Securely connect the air hose to the compressor, ensuring that the hose is damage-free and tightly jointed. The required tightening torque would be in general 15 N m (1.53kg m).

7. TEST FOR SWITCH FUNCTION

- (1) Make sure that the grip bar is screwed in firmly on the polisher body.
- (2) Adjust the pressure of the compressor at 0.4MPa. Higher pressure makes higher speed of polisher, which is not recommendable for this function test.
- (3) Hold the grip bar (see Figure 4, page 7) by one hand while pushing the switch lock by a finger of another hand. Then, push the switch lever down to turn ON. Release the finger from the switch lever to turn OFF while holding the grip bar and the end case by the hands. The polisher is stopped automatically and immediately. In addition, the switch lever is locked by the switch lock automatically (see Figure 8, page 16).

8. TURNING OFF THE POLISHER

Before connecting the air hose to the compressor, ensure that the polisher is locked at OFF position. Or, it would cause sudden start of the polisher. This is very hazardous. When putting the polisher on floor or worktable, make sure to turn the switch lever to OFF position (see Figure 8, page 16).

9. TEST RUN

 WARNING
<ul style="list-style-type: none">· CONNECT THE AIR HOSE SECURELY Disconnection of the air hose during operation could result in hazardous whipping of the air hose. Connect the air hose securely. In addition, when connecting the air hose to the compressor, ensure the switch lever is locked at OFF position.· DO NOT TOUCH THE ROTATING PARTS Do not access to the flexible polishing pad and the rotating parts while the polisher is in running.· MAKE TEST RUN BEFORE POLISHING When the polisher has reached the rotations for use after start, ensure no inordinate noise and/or vibration. For the test run time, refer to TEST RUN TIME in page 14. Polishing without test run could cause injuries.· FOLLOW THE RECOMMENDED SPEED OF POLISHER FOR THE TEST RUN The recommended speed of polisher for the test run shall be smaller than the maximum operating speed of flexible polishing pad, specified by its manufacturer.· DO NOT CARRY OUT TEST RUN OPERATION IN IMPROPER PLACE Test run in improper place is hazardous. Secure stable scaffolding and hold the operator's body in stable position all the times.· STOP THE POLISHER IMMEDIATELY IN CASE OF UNINTENDED REACTION SHOWN Stop the polisher immediately if something inordinate condition is found during run.

 CAUTION

- NO CONTACT WITH ROTATING PARTS DURING TEST RUN
When switching ON, ensure that the flexible polishing pad is not in contact with a work piece and any substances. Such contacts could cause injuries.
- DURING TEST RUN, ANY OTHER PEOPLE SHALL KEEP AWAY
Only limited person, however, who is allowed to access to the test run area by management, would be possible to access the test run area.
- BE CAREFUL NOT TO DAMAGE THE AIR HOSE AND THE WATER HOSE

- (1) Referring to Figure 5 in page 8, adjust the pressure of compressed air so that it rotates at the speed specified by the manufacturer of flexible polishing pad.
- (2) Close the airflow control valve fully and open again slightly.
- (3) Turn ON the switch lever
- (4) Adjust the airflow control valve slowly until it opens completely little by little
- (5) With this condition, make test run for the specified period of test run time described below in this page.

Continuing the test run and/or polishing operation with the damaged flexible polishing pad will be very hazardous. Before starting test run, ensure that any other person is not around and the polisher is in proper condition while test run.

TEST RUN TIME :

Whenever flexible polishing pad is replaced —— more than 3 minutes

Whenever daily polishing operation is started —— more than 1 minute

•HOW TO POLISH

 WARNING

- **TURN OFF THE SWITCH LEVER**
Whenever interrupting the polishing operation and replacing the flexible polishing pad, and after finishing the operation, turn OFF the switch lever and disconnect the air hose from the compressor.
- **USE A PAIR OF PROTECTIVE GLASSES DURING POLISHING OPERATION**
Inordinate impact to the polisher or the flexible polishing pad could result in tear and/or crack of the pad. Handle them with good care. In case the polisher body is dropped or hit against other substances, make sure to inspect that the flexible polishing pad is crack-free and the polisher body is damage-free. If they are cracked or damaged, stop using the polisher.
- **CONNECT THE AIR HOSE SECURELY**
Disconnection of the air hose during operation could result in hazardous whipping of the air hose. Connect the air hose securely. In addition, when connecting the air hose to the compressor, ensure the switch lever is locked at OFF position.
- **DO NOT TOUCH THE ROTATING PARTS**
Do not access to the flexible polishing pad and the rotating parts while the polisher is in running.
- **MAKE TEST RUN BEFORE POLISHING**
When the polisher has reached the rotations for use after start, ensure no inordinate noise and/or vibration. For the test run time, refer to TEST RUN TIME in page 14. Polishing without test run could cause injuries.
- **FIX FIRMLY THE WORK PIECE USING CLMAP AND/OR EQUIVALENTS**
Failure to be fixed could cause an incidental drop of the work piece, in the worst case, injuries.
- **DO NOT CARRY OUT POLISHING OPERATION IN IMPROPER PLACE**
Polishing in improper place is hazardous. Secure stable scaffolding and hold the operator's body in stable position all the times.
- **DO NOT POLISH EXCEPT SPECIFIED OPERATING CONDITIONS**
Do not operate the polisher exceeding the rated rotational speed and maximum operating pressure of compressed air indicated on the nameplate and in the instruction manual. Failure to do so could cause damage of the polisher and flexible polishing pad, in the worst case, injuries.
- **STOP THE POLISHER IMMEDIATELY IN CASE OF UNINTENDED REACTION SHOWN**
Stop the polisher immediately if something inordinate condition is found during run.
- **PAY SPECIAL ATTENTION DURING POLISHING OPERATION**
Do not use the polisher when operator feels fatigue or find an adverse effect of medicine or alcohol.

⚠ CAUTION

- DO NOT DAMAGE THE FLEXIBLE POLISHING PAD AND THE POLISHER
Careless drop or hit of the polisher against other substances could cause damage, cracking and deformation of the flexible polishing pad and the polisher. In such a case, ensure that it is free from such defects before operating. Failure to follow this caution could cause injuries.
- PAY ATTENTION TO EXHAUSTING DIRECTION
Exhausted air might contain motor oil, which could cause accidents and/or oil disease. Take good care not to directly expose the eyes and ears to the exhausted air.
- BE CAREFUL NOT TO DAMAGE THE AIR HOSE AND THE FLEXIBLE WATER HOSE
- MAKE SURE THAT THE FLEXIBLE WATER HOSE IS CONNECTED TIGHTLY
Failure to do so would possibly result in dry-mode operation due to lack of water, causing fire and respiratory diseases at throat and lungs.

1. CONNECTION FOR WATER SUPPLY

Connect the flexible water hose to the hose nipple on the polisher body (see Figure 6, page 11) and to the water source. Adjust the water flow rate by the water-flow control valve so that the work piece and the flexible polishing pad is cooled enough and that polishing effect is optimized.

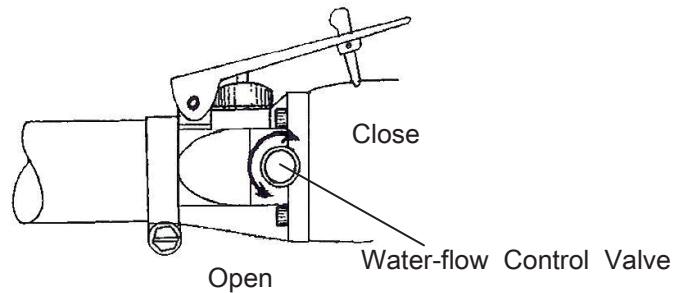

Figure 7 Water-flow Control Valve

2. SWITCH OPERATIONS

- ON position for polishing — Grip the polisher body with the switch lock while pushing it forward together with the switch lever
- OFF position to stop polishing — Grip off the switch lever

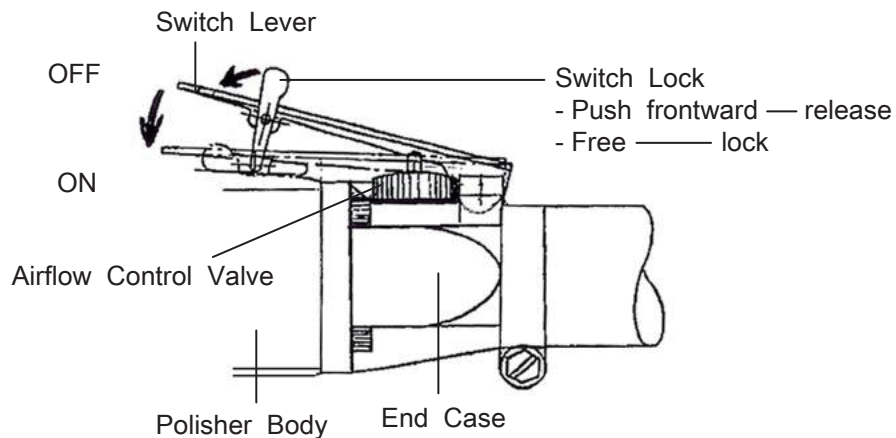

Figure 8 Switch Operations

Adjust airflow rate by turning the airflow control valve in the range MIN position to MAX position shown in Figure 9. Turning it over MAX position to STOP position reduces the airflow rate due to valve structure.

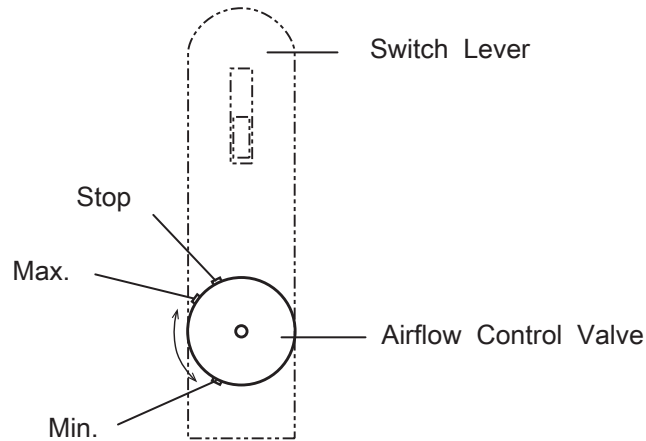

Figure 9 Airflow Control Valve

3. HOW TO POLISH A WORK PIECE WITH THE FLEXIBLE POLISHING PAD

When the polisher rotation gets stable after the start, begin the polishing operation, Put the flexible polishing pad slowly on the face to be polished when it comes in touch with a work piece. Too much force to the pad would damage the work piece and cause quick worn-out of the pad, and would not be an efficient polishing.

The efficient polishing depends on many elements, characteristics of work piece, the flexible polishing pad, pressure between the flexible polishing pad and work piece, water flow rate, skill of operator and polisher speed.

The operator would have an experience of optimum water flow rate. Contact of polisher speed is utilized by airflow control value (see Figure 1, page 6) The optimum polishing speed, therefore, could not be specified in this instruction manual due to too many elements.

Relation of r/min and compressed air pressure is shown in Figure 5 in page 8. The operator would have an experience of optimum polisher speed.

4. CAUTIONS IMMEDIATELY AFTER USE

After the polishing operation, turn OFF the switch lever and place the polisher on floor ensuring that its rotation is completely stopped. Failure to do so could cause accidents. Inordinate impact to the polisher body could result in tear or crack of the polisher and the flexible polishing pad. Handle them with good care.

•AFTER USE

 WARNING

- | |
|--|
| <ul style="list-style-type: none">· USE DESIGNATED PARTS IN THIS INSTRUCTION MANUAL
Use only the parts shown in this instruction manual when accessories are replaced. |
|--|

 CAUTION

- | |
|---|
| <ul style="list-style-type: none">· EXECUTE AN ADEQUATE MAINTENANCE
Remove dust from the polisher and keep it clean. Particularly take good care to protect the connections with the compressor and polisher from contamination of oil except ISO-VG46 or DIN51502DL46, water and dust.· HANDLE THE AIR HOSE WITH GOOD CARE
Do not carry the polisher with its air hoses, flexible water hose and exhaust air duct in hand and do not add any tension to these hoses and duct. Doing so would cause damage of these hoses and duct. Furthermore, be away from heat, oil and article with sharp edge. |
|---|

1. DISCONNECT THE AIR HOSE

- (1) Close the stop-valve on the compressor
- (2) Turn OFF the polisher by switch lever
- (3) Disconnect the air hose and exhaust air duct hose
- (4) Disconnect the flexible water hose from water source
The flexible water hose does not need to be disconnected from the polisher body

2. EXECUTE AN ADEQUATE MAINTENANCE

Execute an adequate maintenance, referring MAINTENANCE AND CHECK in page 19

3. STORE THE POLISHER AT SAFE, CLEAN AND DRY PLACE

After cleaning out dust and mist from the polisher, store it at safe, clean and dry place.

Furthermore, do not store it at the following places;

- where children reach or take it easily
- where temperature and humidity fluctuate rapidly
- where the polisher is exposed to rain or high humidity
- where the polisher is exposed to direct sun ray

MAINTENANCE AND CHECK

 WARNING
· DISCONNECT THE AIR HOSE FROM THE COMPRESSOR WITHOUT FAIL Failure to do so could result in incidental start of the polisher, in the worst case, lead to an unexpected accident.

Retightening :
(every time before use)

Make sure each mounted screw is not loose and missed. Operating the polisher with such screws could result in accidents. Retighten the screws without fail.

Removal of dust and water content (drain) :
(every time before use as necessary)

The compressed air containing dust and condensed air could cause trouble of the polisher. Completely drain out condensed water before storage.

Dust filter is recommended to apply compressor to remove the dust and automatic draining device to remove the condensed water.

Oiling :
(every time after use)

After use, supply 1mm³ of specific air motor oil into the polisher body through the air inlet (see hose joint (male) in Figure 6, page 11).

Cleaning :
(every time after use)

Apply careful cleaning to the polisher for complete removal of dust and small stones in order to prevent inclusion of them into the motor. While the polisher is in storage, plug the hose joint and hose nipple (see Figure 6, page 11) with caps to prevent invasion of dust and mist.

TROUBLESHOOTING

 WARNING
· DO NOT OVERHAUL THE POLISHER BY YOURSELF Overhaul of the polisher by yourself could result in imperfection, in the worst case, would cause accidents and injuries.